

J-DRain[®] "Thin Drain"

Under Tile Drainage

Physical Properties

Core				
Thickness	Width	Length	Compression	Flow Rate
0.125"	48"	100'	15,000 psf	7 gal/min/ft

Fabric			
Grab Tensile	AOS	Puncture	Flow Rate
100 lbs.	70 U.S. Sieve	65 lbs.	140 gal/min/ft ²



Product Description

J-DRain "Thin-Drain" is a 3-dimensional composite drainage system designed for applications that have a limited "height tolerance". Many indoor and outdoor thin-set applications must maintain a limited height tolerance due to door swings or to match up to other floor surfaces. **J-DRain "Thin Drain"** only adds 1/8" to the total thickness of thin-set application while allowing for the easy collection and removal for water and/or moisture.

Product Applications

- ◆ Outdoor Patios, Decks & Terraces
- ◆ Bathroom floors, Showers, Kitchens, Foyers & Sun rooms
- ◆ Underlayment for carpet applications on concrete floors
- ◆ Horizontal applications with limited height restrictions

Product Features

- ◆ Easy installation
- ◆ Creates air void under tile for drainage
- ◆ Ultra low profile - 1/8" total thickness
- ◆ Protects membrane
- ◆ Made in USA
- ◆ Filter fabric prevents clogging

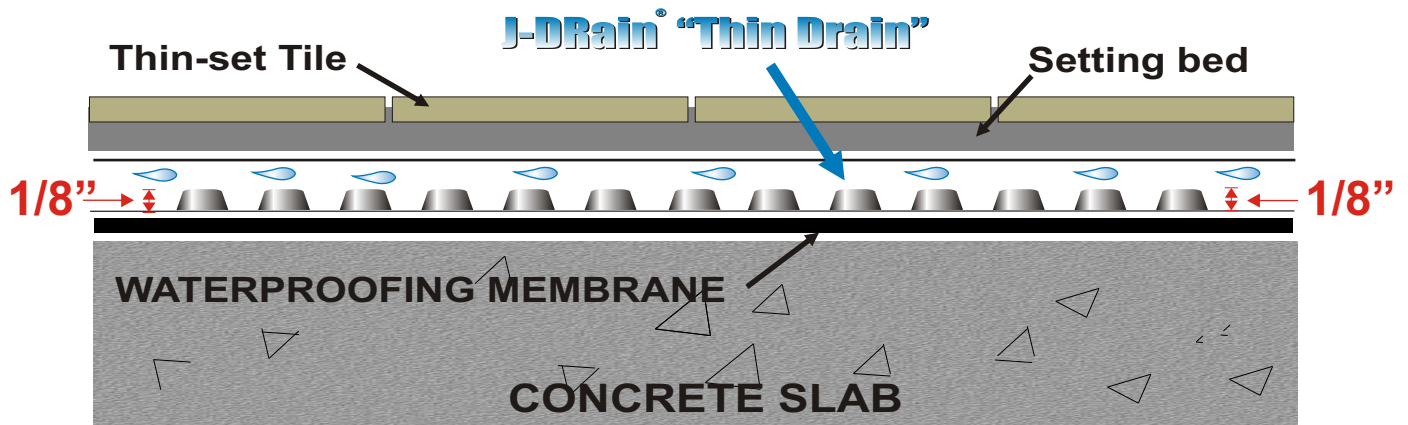

info@j-drain.com

www.j-drain.com

JDR Enterprises, Inc.

292 S. Main St., Suite 200 Alpharetta, GA 30009
(800) 843-7569 (770) 442-1461 Fax: (770) 664-7951